



Solar Rating & Certification Corporation

500 New Jersey Avenue, NW
Sixth Floor
Washington, DC 20001
t: 888.ICC.SAFE (422.7233)
t: 202.370.1800
f: 202.783.2348
www.solar-rating.org

SWCC Summary Report

Manufacturer: **Bergey Windpower Company**
Wind Turbine Model: **Excel 10** (240 VAC, 1-phase, 60 Hz)
Certification Number: **SWCC-10-12**



The above-identified Small Wind Turbine is certified by the Solar Rating & Certification Corporation - Small Wind Certification Program to be in conformance with the AWEA *Small Wind Turbine Performance and Safety Standard* (AWEA Standard 9.1 – 2009). For the SWCC Certificate visit: www.smallwindcertification.org

This report summarizes the results of testing and certification of the Bergey Windpower Company Excel 10 in accordance with AWEA Standard 9.1-2009. The Excel 10 is a 3-blade, upwind, horizontal axis wind turbine with a swept area of 38.5 m². The tested configuration utilized a Powersync II inverter and a Bergey 30 m (100 ft) guyed-lattice tower. Field tests were conducted at the USDA/ARS facility in Bushland, Texas from June 24, 2010 to March 18, 2011.

1. Turbine Ratings

The Excel 10 performance testing was conducted in accordance with Section 2 of AWEA Standard 9.1-2009. The resulting turbine ratings, tabulated graphical Annual Energy Production (AEP), and graphical and tabulated power curve are given below.

AWEA Rated Annual Energy @ 5 m/s	13,800 kWh
AWEA Rated Sound Level	42.9 dB(A)
AWEA Rated Power @ 11 m/s	8.9 kW
Peak Power @ 16.5 m/s	12.6 kW

2. Tabulated Annual Energy Production (AEP)

Corrected to a sea level air density of 1.225 kg/m³

Hub Height Annual Average Wind Speed (m/s)	AEP Measured (kWh)	Standard Uncertainty in AEP (kWh)	Standard Uncertainty in AEP (%)	AEP Extrapolated (kWh)
4	7,135	503	7.05	7,135
5	13,842	884	6.39	13,842
6	22,300	1,281	5.74	22,300
7	31,342	1,604	5.12	31,342
8	39,755	1,824	4.59	39,755
9	46,652	1,944	4.17	46,652
10	51,626	1,982	3.84	51,626
11	54,685	1,961	3.59	54,685

3. Annual Energy Production Curve

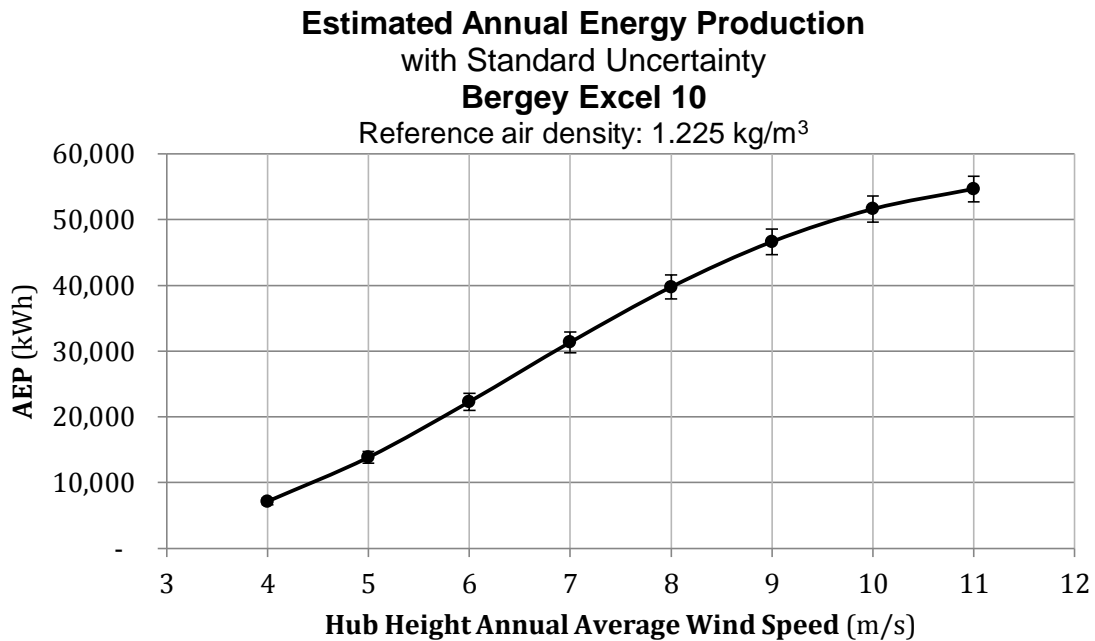

4. Power Curve

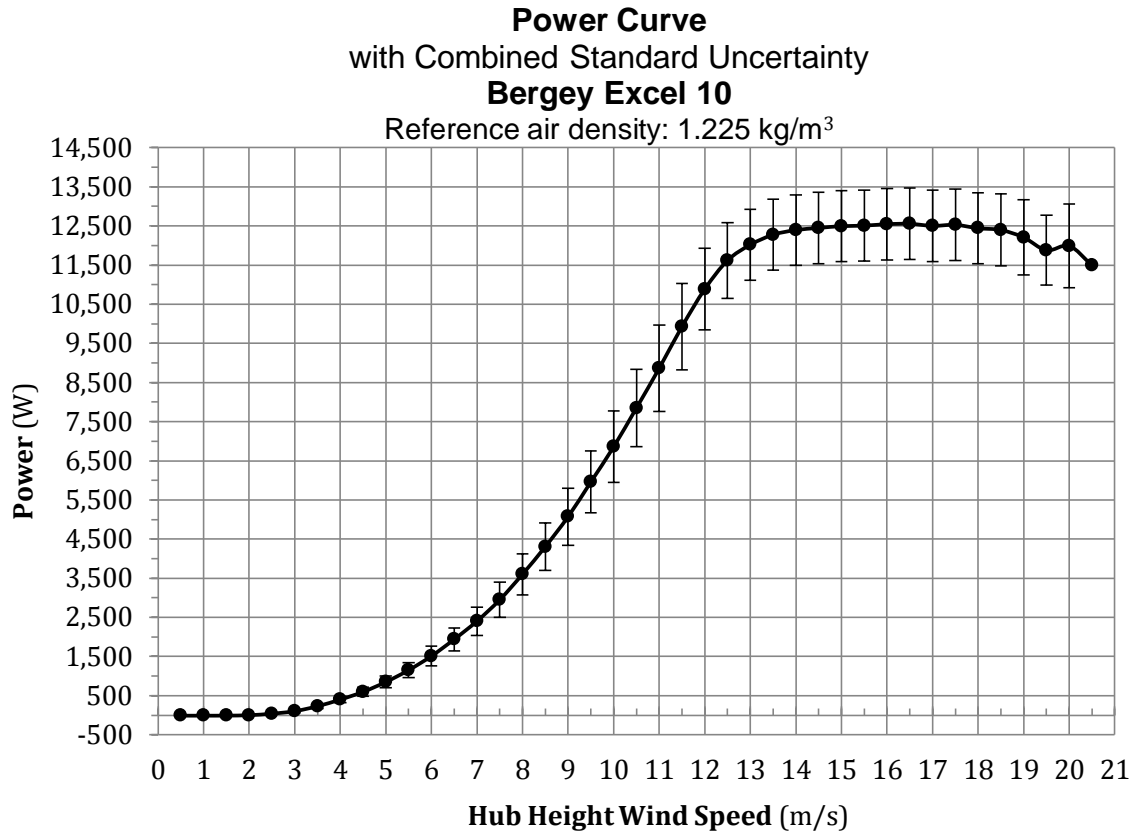

5. Tabulated Power Curve

Corrected to a sea level air density of 1.225 kg/m ³					Category A	Category B	Combined
Bin No.	Hub Height Wind Speed	Power Output	Cp	1-minute samples	Standard Uncertainty, Si	Standard Uncertainty, Ui	Standard Uncertainty, Ci
	<i>m/s</i>	<i>Watts</i>			<i>Watts</i>	<i>Watts</i>	<i>Watts</i>
1	0.5	-12		158			
2	1.0	-12		224	0.1	0.9	0.9
3	1.5	-11		309	0.3	0.9	1.0
4	2.0	0		391	0.9	2.9	3.0
5	2.5	39	0.11	375	2.1	10.9	11.1
6	3.0	102	0.16	661	3.0	20.2	20.4
7	3.5	229	0.23	818	3.4	43.8	43.9
8	4.0	399	0.26	1060	3.2	65.4	65.4
9	4.5	596	0.28	1213	3.0	84.5	84.6
10	5.0	848	0.29	1235	3.7	116.9	117.0
11	5.5	1,151	0.29	1279	4.7	152.6	152.6
12	6.0	1,510	0.30	1250	5.4	195.2	195.3
13	6.5	1,938	0.30	1401	6.0	248.5	248.6
14	7.0	2,403	0.30	1355	7.1	293.3	293.4
15	7.5	2,949	0.30	1014	9.9	362.8	362.9
16	8.0	3,602	0.30	885	12.7	452.4	452.6
17	8.5	4,306	0.30	687	16.8	523.1	523.3
18	9.0	5,071	0.30	736	18.0	604.1	604.4
19	9.5	5,960	0.29	668	19.7	725.9	726.1
20	10.0	6,856	0.29	707	21.4	790.8	791.0
21	10.5	7,849	0.29	650	26.2	912.1	912.5
22	11.0	8,863	0.28	599	28.0	994.0	994.4
23	11.5	9,928	0.28	635	24.3	1098.6	1098.9
24	12.0	10,885	0.27	606	24.8	1105.8	1106.1
25	12.5	11,619	0.25	504	21.7	1044.8	1045.0
26	13.0	12,019	0.23	432	15.0	968.6	968.7
27	13.5	12,276	0.21	337	13.3	906.1	906.2
28	14.0	12,395	0.19	333	7.4	906.0	906.1
29	14.5	12,449	0.17	292	7.2	904.5	904.6
30	15.0	12,495	0.16	279	3.3	907.5	907.5
31	15.5	12,508	0.14	231	10.3	907.4	907.4
32	16.0	12,546	0.13	187	5.4	911.0	911.0
33	16.5	12,555	0.12	165	8.5	910.7	910.8
34	17.0	12,503	0.11	125	24.4	908.8	909.1
35	17.5	12,528	0.10	138	17.8	909.2	909.4
36	18.0	12,442	0.09	98	36.2	908.2	908.9
37	18.5	12,396	0.08	94	36.8	901.0	901.7
38	19.0	12,208	0.08	57	65.2	916.2	918.5
39	19.5	11,878	0.07	39	83.4	960.0	963.6
40	20.0	11,989	0.06	18	130.0	882.0	891.5
41	20.5	11,495	0.06	15	124.6	1066.4	1073.7

6. Tabulated Acoustic Data

Wind Speed @ 10m Height m/s	Background Sound Pressure Level (SPL) dB(A)	Corrected Bergey Excel SPL dB(A)	* indicates delta dB between 3 & 6 dB	Bergey Excel SPL Std. Dev. dB	Corrected Sound Power dB(A)
6	38.53	42.38	*	1.37	80.57
7	39.85	44.23	*	1.52	82.42
8	41.36	46.71		1.91	84.90
9	43.32	49.25		1.95	87.44
10	44.91	51.99		1.81	90.18

7. Graphical Acoustic Data

Scatter Plot of Bergey 10 kW Acoustical Data (HH=30.5m, Bushland, TX)
Aug. 15, 2011 (Background), Sep. 12 & Oct. 3 of 2011 (Bergey 10 kW)

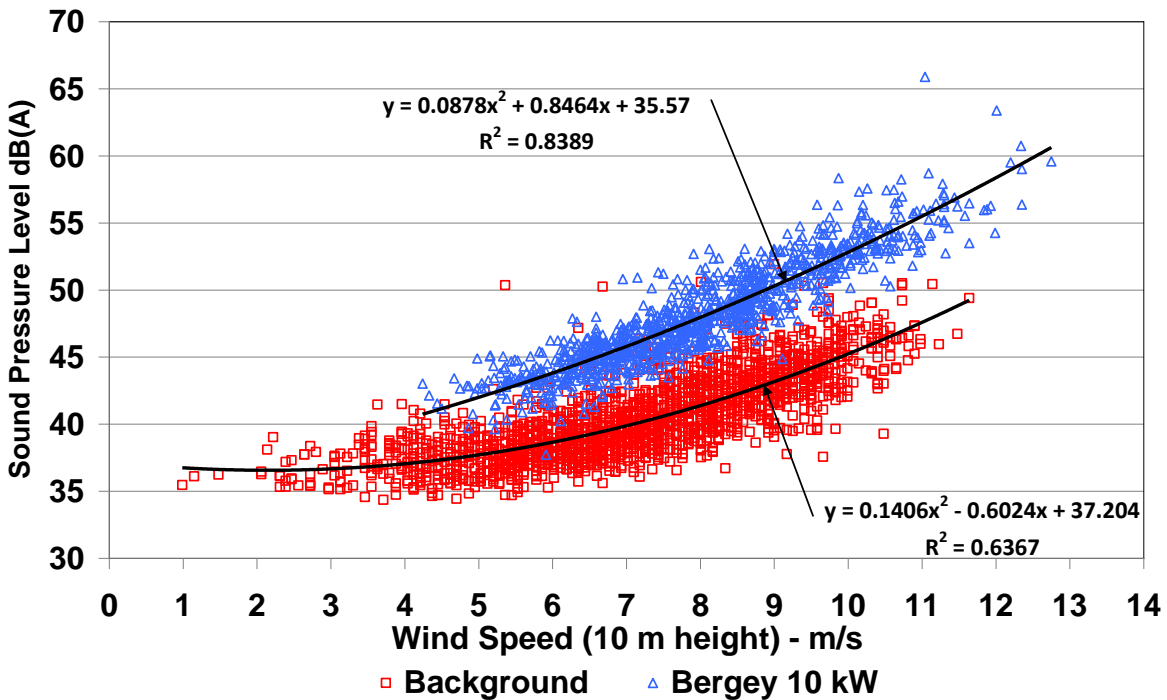

Acoustical Data Collected on Bergey 10 kW Grid-tie WT, 30.5 m tower USDA-ARS Lab near Bushland, TX (Aug/Sep/Oct 2011)

Note: Sound Pressure Level corrected for background (eqn. 8 of Ref. IEC 61400-11).

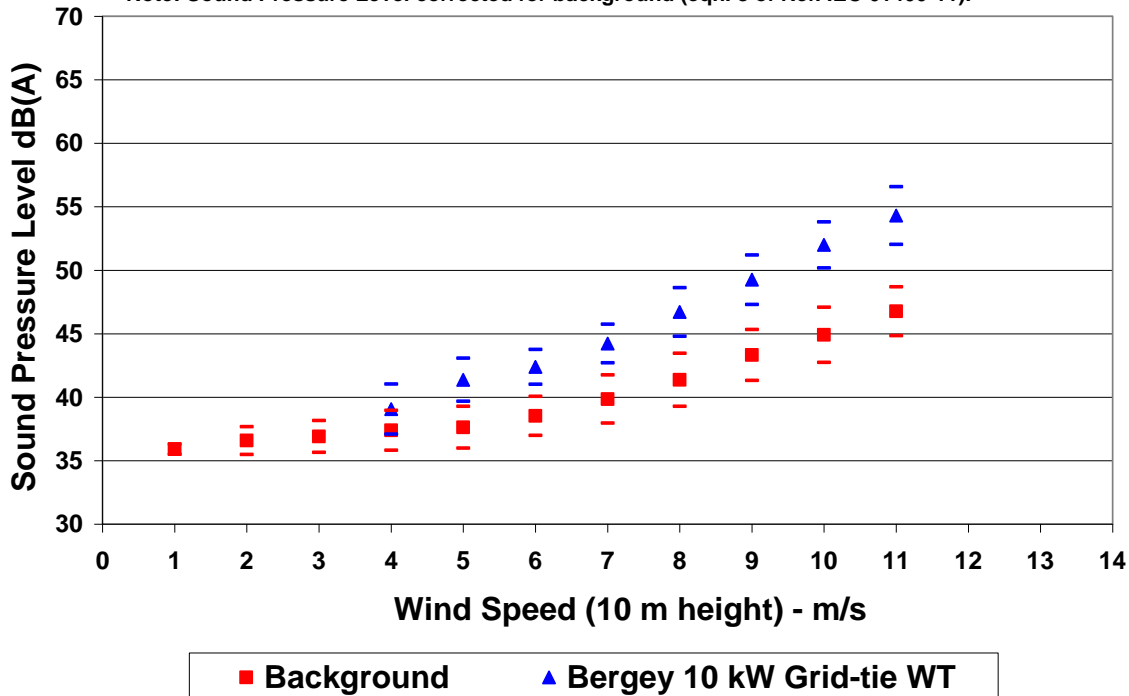

8. Duration Testing

The Bergey Excel 10 successfully completed a Duration Test for an IEC Class II Small Wind Turbine. The testing was performed from June 24, 2010 to March 18, 2011 with an Operational Time Fraction of 100%. The highest instantaneous wind speed recorded during the test was 31.6 m/s (70.7 mph). The average turbulence intensity at 15 m/s was 8.4%.

9. Mechanical Strength Analysis

The mechanical strength analysis was found to be in conformance with IEC 61400-2 as modified by section 4 of AWEA Standard 9.1 – 2009 for an IEC Class II Small Wind Turbine.

10. Safety and Function testing

Safety and Function testing was found to be in conformance with sections 4.3 and 4.4 of AWEA Standard 9.1 – 2009.

11. Manufacturer Tower Design Requirements (SRCC is not responsible for any errors in the document below, which is provided by the manufacturer).

BASIC TOWER REQUIREMENTS for the BWC EXCEL WIND TURBINE

Customer supplied towers for the BWC EXCEL should meet the following requirements:

- Tower Height:** 60 ft (18 m) minimum, 80 ft (24 m) or higher recommended
Design Wind Speed: 120 mph (54 m/s)
Turbine Weight: 1200 lb (545 kg)
Turbine Thrust Load: 2400 lb (1090 kg) @ any wind \geq 40 mph (18 m/s)
Blade Clearance: The top 12 ft (3.5 m) of the tower must not extend beyond an 18 inch (0.46 m) radius from the tower centerline.
Tower Plumb Tolerance: Up to 0.25° tolerance from plumb allowed.
Tower Stiffness: Tilt at the top of the tower should be no more than 2.0° for consistent furling. Deflection of monopole towers at 50 mph should be no more than 1.0% of tower height; at 120 mph no more than 2.5% of tower height. (For a 120 ft tower this would be 14.4 in and 36.0 in, respectively.) Overly flexible towers can cause vibration and/or fatigue problems. A civil engineer should approve the tower.

Blade Frequency:

First Flap Frequency for 10 kw (Not Rotating)			Blade Length	
Tested: 8/4/2011				
Ferrite	3.012	Hz	128	in.
Neo	2.703	Hz	134	in.

Turbine Mounting:

- Provisions shall be made for mounting a furling winch, strain relief for tower wiring, tower climbing, anti-fall equipment and access holes where appropriate.
- The top of the tower shall be designed to allow the connection of the power cable and furling cable to the turbine via the two 2.3" diameter holes in the turbine's tower adapter plate.
- A connection shall be made between the turbine furling cable and the tower furling winch by using a tower furling cable assembly (11508-x), a 3/16" stainless steel thimble (HM3003) and two 3/16" stainless steel malleable clips (HM3002-B).
 - Furling cable, thimble, and clips must be purchased separately.
- Tower connection shall be made using either nine 5/8" bolts or six 3/4" bolts using the pattern illustrated below:

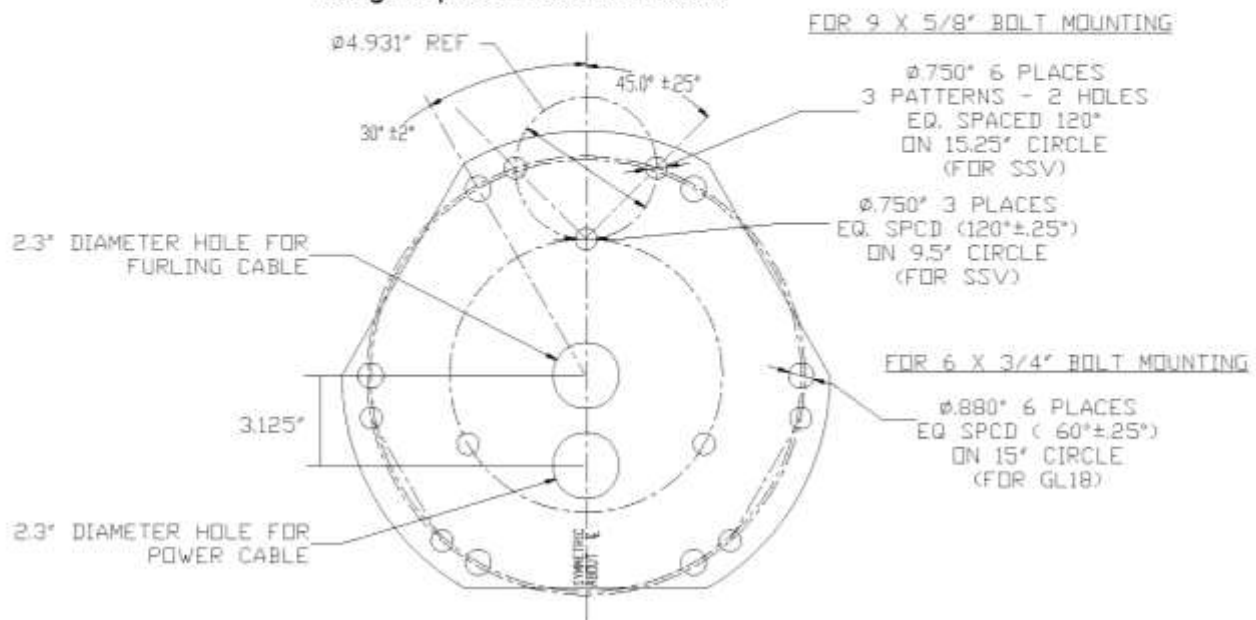

©2017 Solar Rating & Certification Corp™